

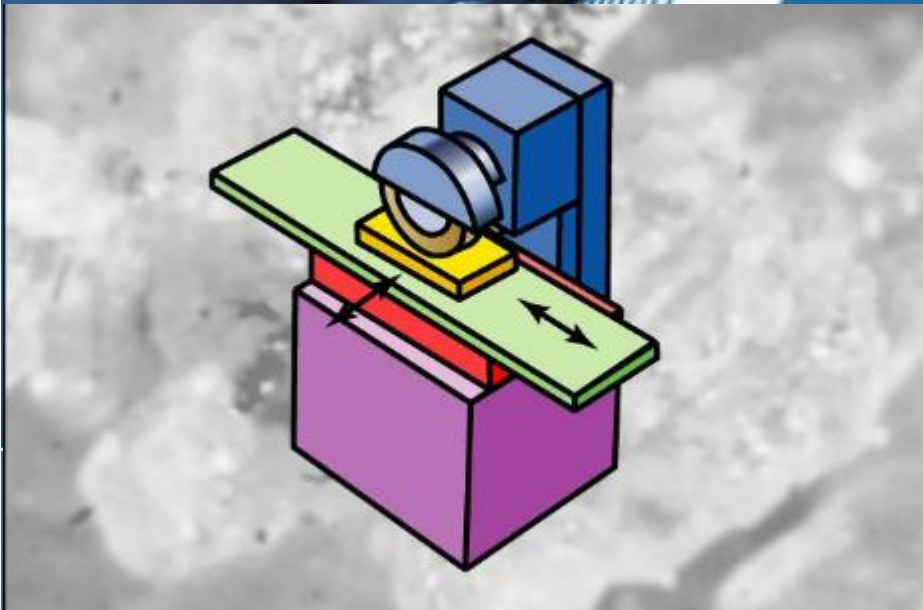

Chapter 26

Abrasive Machining and Finishing Operations



Dr. Juma Yousuf Alaydi

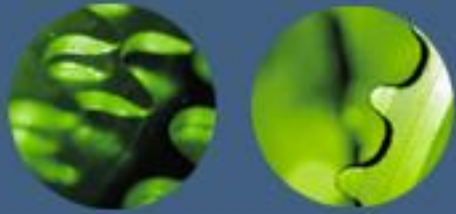

Abrasive Machining and Finishing Operations

- There are many situations where the processes of manufacturing we've learned about cannot produce the required dimensional accuracy and/or surface finish.
 - Fine finishes on ball/roller bearings, pistons, valves, gears, cams, etc.
 - The best methods for producing such accuracy and finishes involve **abrasive machining**.



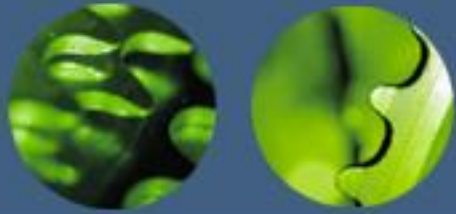

Abrasives and Bonded Abrasives

- An abrasive is a small, hard particle having sharp edges and an irregular shape.
- Abrasives are capable of removing small amounts of material through a cutting process that produces tiny chips.

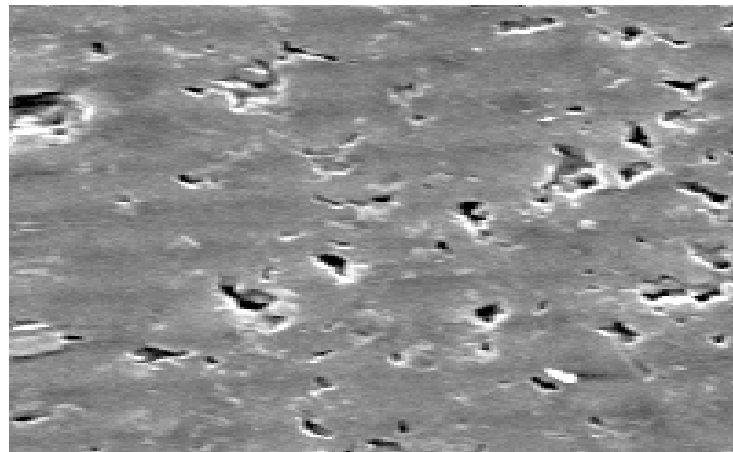

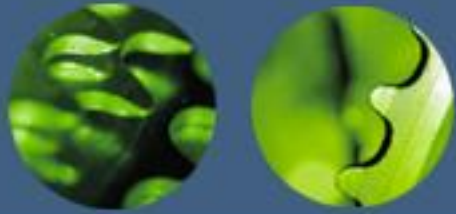

Abrasives and Bonded Abrasives

- Commonly used abrasives in abrasive machining are:
 - Conventional Abrasives
 - Aluminum Oxide
 - Silicon Carbide
 - Superabrasives
 - Cubic boron nitride
 - Diamond

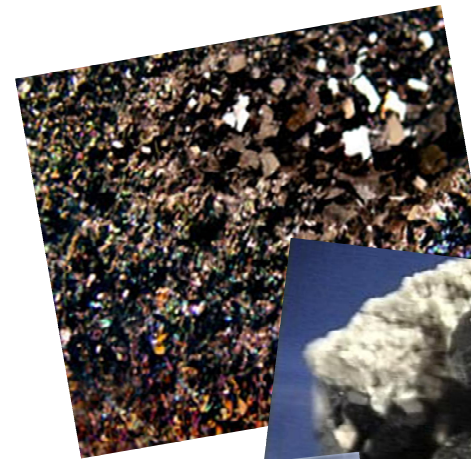

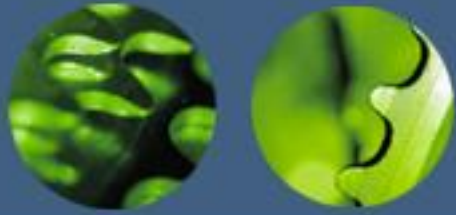

Friability

- Characteristic of abrasives.
- Defined as the ability of abrasive grains to fracture into smaller pieces, essential to maintaining sharpness of abrasive during use.
- High friable abrasive grains fragment more under grinding forces, low friable abrasive grains fragment less.



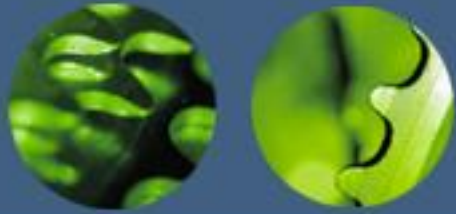

Abrasive Types

- Abrasives commonly found in nature include:
 - Emery
 - Corundum
 - Quartz
 - Garnet
 - Diamond



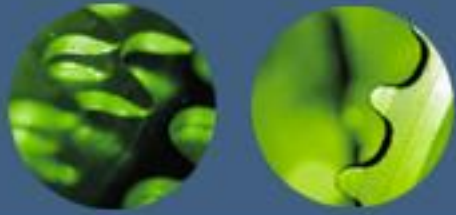

Abrasive Types

- Synthetically created abrasives include:
 - Aluminum oxide (1893)
 - Seeded gel (1987)
 - Silicon carbide (1891)
 - Cubic-boron nitride (1970's)
 - Synthetic diamond (1955)

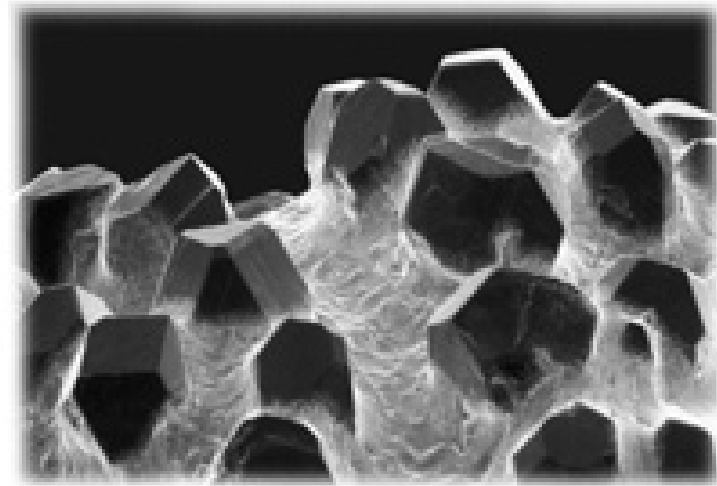

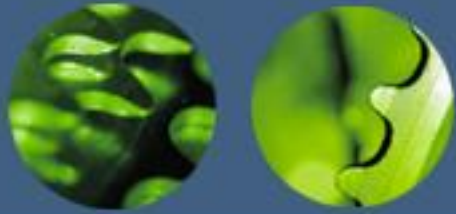

Abrasive Grain Size

- Abrasives are usually much smaller than the cutting tools in manufacturing processes.
- Size of abrasive grain measured by grit number.
 - Smaller grain size, the larger the grit number.
 - Ex: with sandpaper 10 is very coarse, 100 is fine, and 500 is very fine grain.

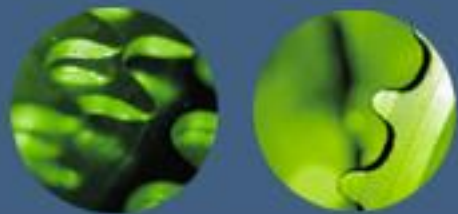

Example: M D 100 – P 100 – B 1/8

Prefix	Abrasive type	Grit size	Grade	Diamond concentration	Bond	Bond modification	Diamond depth (in.)
Manufacturer's symbol (to indicate type of diamond)	B Cubic boron nitride	20	A (soft) to Z (hard)	25 (low)	B Resinoid M Metal V Vitrified	Absence of depth symbol indicates all diamond	1/16
	D Diamond	24		50			1/8
		30		75			1/4
		36		<u>100</u> (high)			
		46					
		54					
		60					
		80					
		90					
		<u>100</u>					
		120					
		150					
		180					
		220					
	240						
	280						
	320						
	400						
	500						
	600						
	800						
	1000						

A letter or numeral or combination
 (used here will indicate a variation from standard bond)

Note:
 1/16 in. = 1.6 mm
 1/8 in. = 3.2 mm
 1/4 in. = 6.4 mm

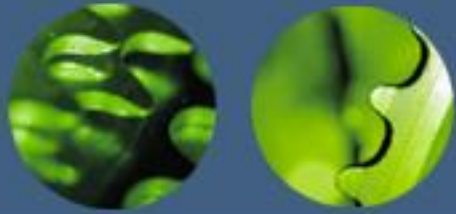

Grinding Wheels

- Large amounts can be removed when many grains act together. This is done by using **bonded abrasives**.
 - This is typically in the form of a grinding wheel.
 - The abrasive grains in a grinding wheel are held together by a **bonding material**.

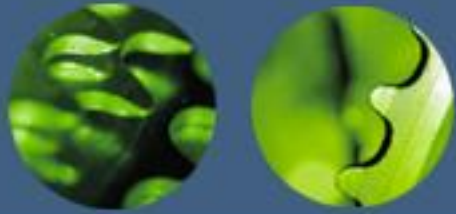

Bonding Abrasives

- Bonding materials act as supporting posts or braces between grains.
- Bonding abrasives are marked with letters and numbers indicating:
 - Type of abrasive
 - Grain size
 - Grade
 - Structure
 - Bond type

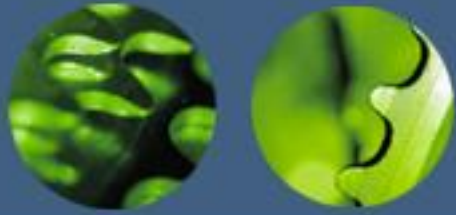

Bond Types

- Vitrified: a glass bond, most commonly used bonding material.
 - However, it is a brittle bond.
- Resinoid: bond consisting of thermosetting resins, bond is an organic compound.
 - More flexible bond than vitrified, also more resistant to higher temps.



Abrasives and Bonded Abrasives:

Bond Types

14

□ Common types of bonds:

1. **Vitrified:**

- Consist of feldspar and clays
- Strong, stiff, porous, and resistant to oils acids, and water

Wheels with vitrified bonds are strong, stiff, porous, and resistant to oils, acids, and water. However, they are brittle and lack resistance to mechanical and thermal shock. To improve their strength during use, vitrified wheels also are made with steel-backing plates or cups for better structural support of the bonded abrasive. The color of the grinding wheel can be modified by adding various elements

2. **Resinoid:**

- Bonding materials are *thermosetting resins*
- Resinoid wheels are more flexible than vitrified wheels

Abrasives and Bonded Abrasives:

Bond Types

15

3. Reinforced Wheels:

- Consist of layers of *fiberglass mats* of various mesh sizes

4. Thermoplastic:

- Used in grinding wheels
- With sol-gel abrasives bonded with thermoplastics

5. Rubber:

- Using powder-metallurgy techniques
- Lower in cost and are used for small production quantities

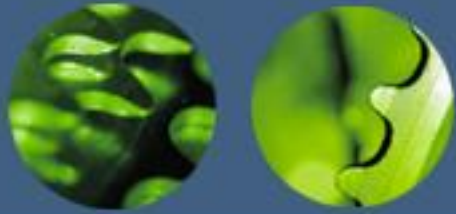

Bond Types

- Reinforced Wheels: bond consisting of one or more layers of fiberglass.
 - Prevents breakage rather than improving strength.
- Rubber: flexible bond type, inexpensive.
- Metal: different metals can be used for strength, ductility, etc.
 - Most inexpensive bond type.

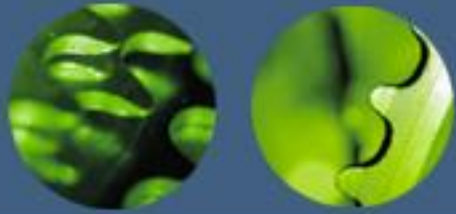

The Grinding Process

- Grinding is a chip removal process that uses an individual abrasive grain as the cutting tool.
- The differences between grinding and a single point cutting tool is:
 - The abrasive grains have irregular shapes and are spaced randomly along the periphery of the wheel.
 - The average rake angle of the grain is typically -60 degrees. Consequently, grinding chips undergo much larger plastic deformation than they do in other machining processes.
 - Not all grains are active on the wheel.
 - Surface speeds involving grinding are very fast.

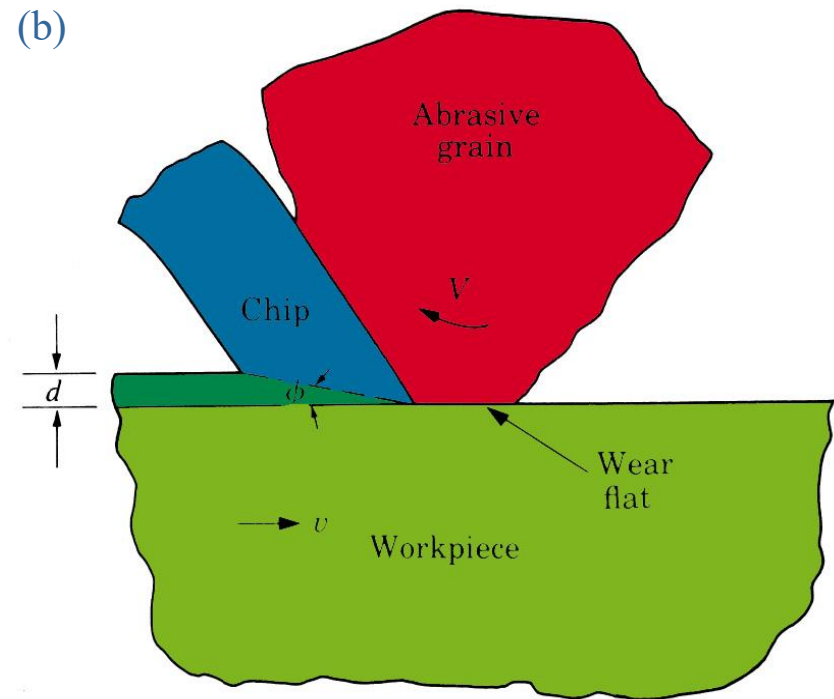
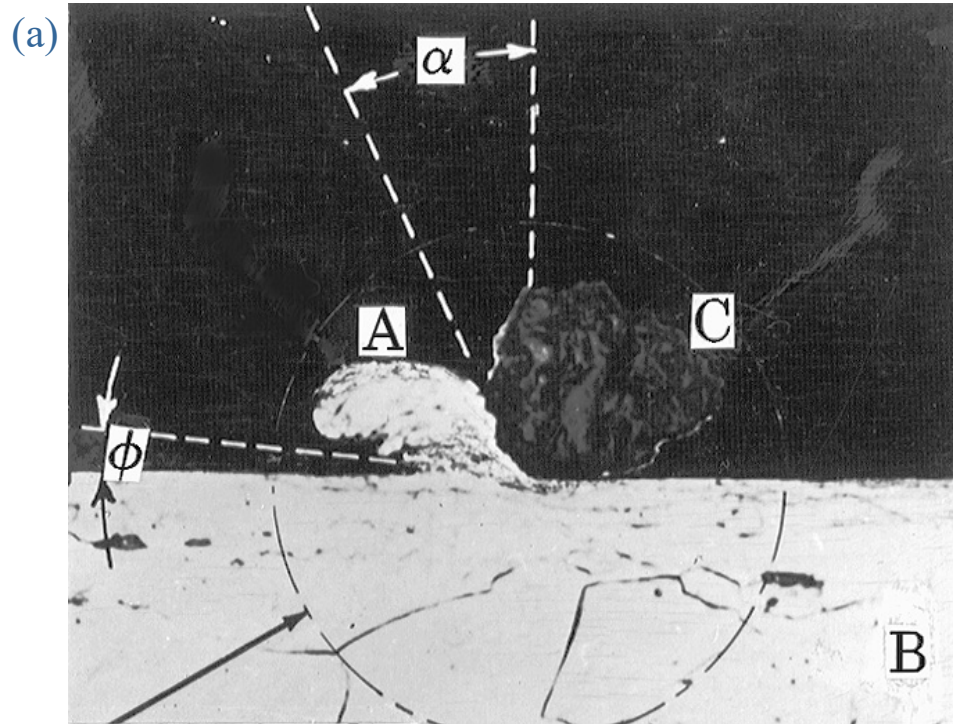
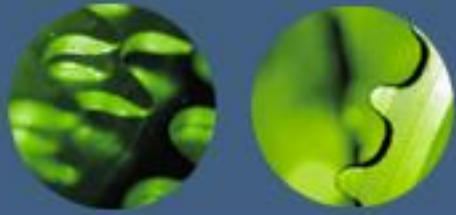

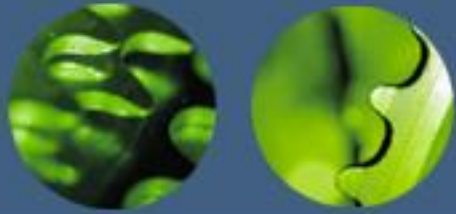

Grinding Forces

- A knowledge of grinding forces is essential for:
 - Estimating power requirements.
 - Designing grinding machines and work-holding fixtures and devices.
 - Determining the deflections that the work-piece as well as the grinding machine may undergo. Deflections adversely affect dimensioning.

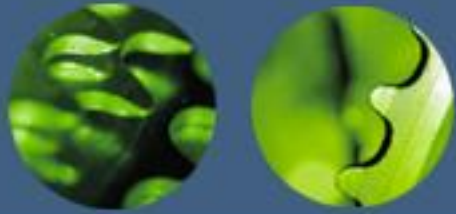

Grinding Forces

- Forces in grinding are usually smaller than those in machining operations because of the smaller dimensions involved.
- Low grinding forces are recommended for dimensional accuracy.

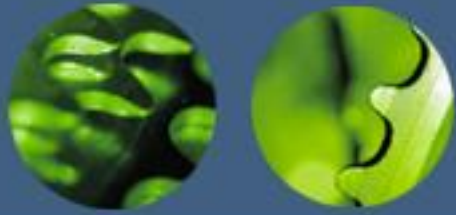

Problems with Grinding

- Wear Flat
 - After some use, grains along the periphery of the wheel develop a **wear flat**.
- Wear flats rub along the ground surface, creating friction, and making grinding very inefficient.

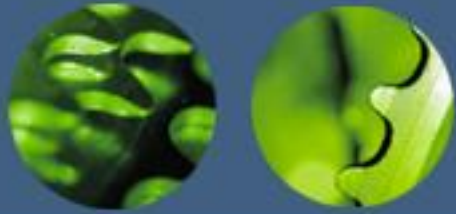

Problems with Grinding

- Sparks
 - Sparks produced from grinding are actually glowing hot chips.
- Tempering
 - Excessive heat, often times from friction, can soften the work-piece.
- Burning
 - Excessive heat may burn the surface being ground. Characterized as a bluish color on ground steel surfaces.

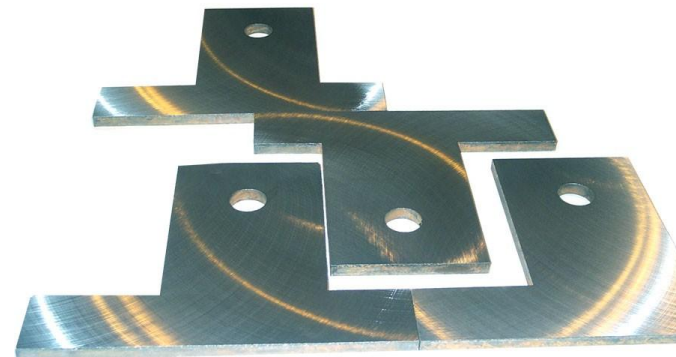

The Grinding Process

23

Sparks

- Sparks produced are chips that glow due to *exothermic* (heat-producing) reaction of the hot chips with oxygen in the atmosphere
- When heat generated due to exothermic reaction is high, chips can melt

Tempering

- Excessive temperature rise in grinding can cause *tempering* and *softening* of the workpiece surface

The Grinding Process

24

Burning

- Excessive temperature during grinding may burn the workpiece surface
- A *burn* is characterized by a bluish color on ground steel surfaces

Heat Checking

- High temperatures in grinding may cause the workpiece surface to develop cracks

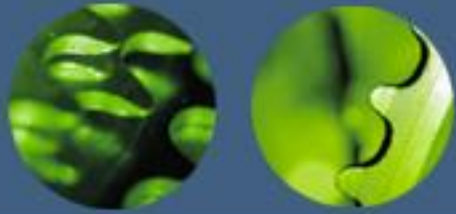

Problems with Grinding

- Heat Checking
 - High temps in grinding may cause cracks in the work-piece, usually perpendicular to the grinding surface.

The Grinding Process: Grinding-wheel Wear

26

Attritious Grain Wear

- Similar to flank wear in cutting tools
- Cutting edges become dull and develop a *wear flat*
- Selection of abrasive is based on the *reactivity* of the grain, workpiece hardness and toughness

Grain Fracture

- The grain should fracture at a moderate rate
- So that new sharp cutting edges are produced continuously during grinding

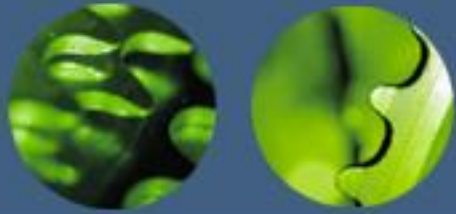

Grain Fracture

- Abrasive grains are brittle, and their fracture characteristics are important.
- Wear flat creates unwanted high temps.
- Ideally, the grain should fracture at a moderate rate so as to create new sharp cutting edges continuously.



The Grinding Process: Grinding-wheel Wear

28

Attritious Grain Wear

- Similar to flank wear in cutting tools
- Cutting edges become dull and develop a *wear flat*
- Selection of abrasive is based on the *reactivity* of the grain, workpiece hardness and toughness

Grain Fracture

- The grain should fracture at a moderate rate
- So that new sharp cutting edges are produced continuously during grinding

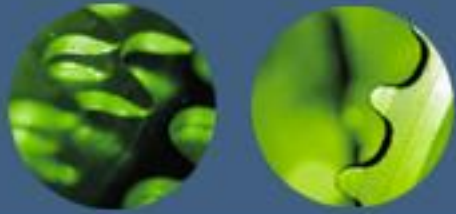

Bond Fracture

- The strength of the abrasive bond is very important!
- If the bond is too strong, dull grains cannot dislodge to make way for new sharp grains.
 - Hard grade bonds are meant for soft materials.
- If too weak, grains dislodge too easily and the wear of the wheel increases greatly.
 - Soft grade bonds are meant for hard materials.

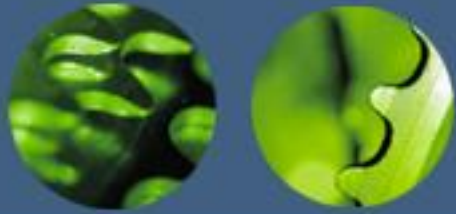

Grinding Ratio

- $G = (\text{Volume of material removed}) / \text{Volume of wheel wear}$
- The higher the ratio, the longer the wheel will last.
- During grinding, the wheel may act “soft” or “hard” regardless of wheel grade.
 - Ex: pencil acting hard on soft paper and soft on rough paper.

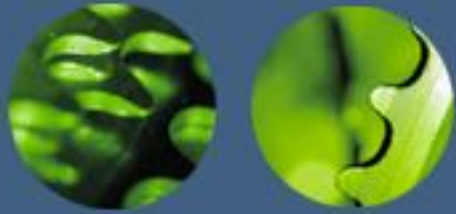

Dressing, Truing, Shaping

- “Dressing” a wheel is the process of:
 - Conditioning worn grains by producing sharp new edges.
 - Truing, which is producing a true circle on the wheel that has become out of round.
- Grinding wheels can also be shaped to the form of the piece you are grinding.
- These are important because they affect the grinding forces and surface finish.

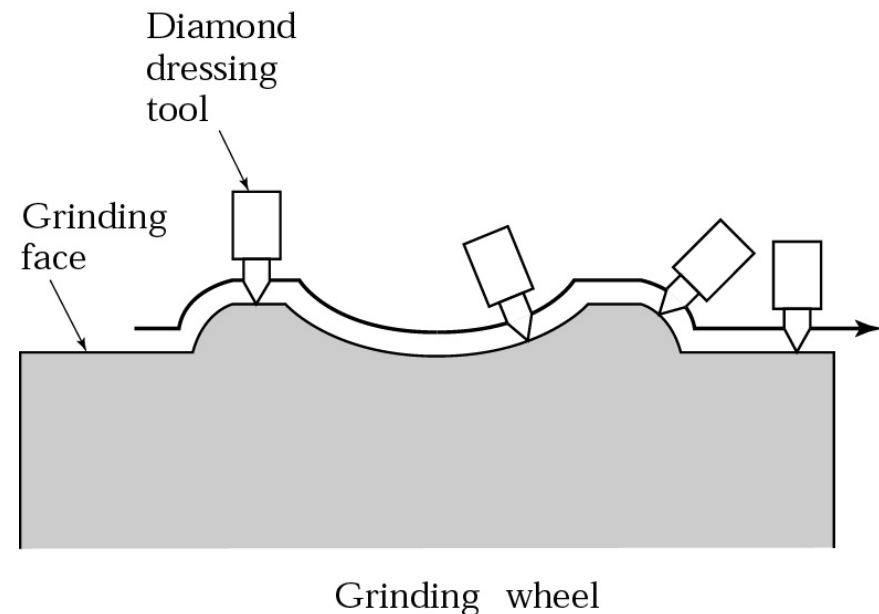

The Grinding Process: Dressing, Truing, and Shaping of Grinding Wheels

32

- *Dressing* is the process of:
 1. *Conditioning*
 2. *Truing*
- Dressing is required for dulls wheel or when the wheel becomes loaded
- **Loading** occurs when the porosities on the wheel surfaces become filled with chips from the workpiece
- Dressing techniques and their frequency affect grinding forces and workpiece surface finish
- Grinding wheels can be **shaped** to the form to be ground on the workpiece

The Grinding Process: Dressing, Truing, and Shaping of Grinding Wheels

33

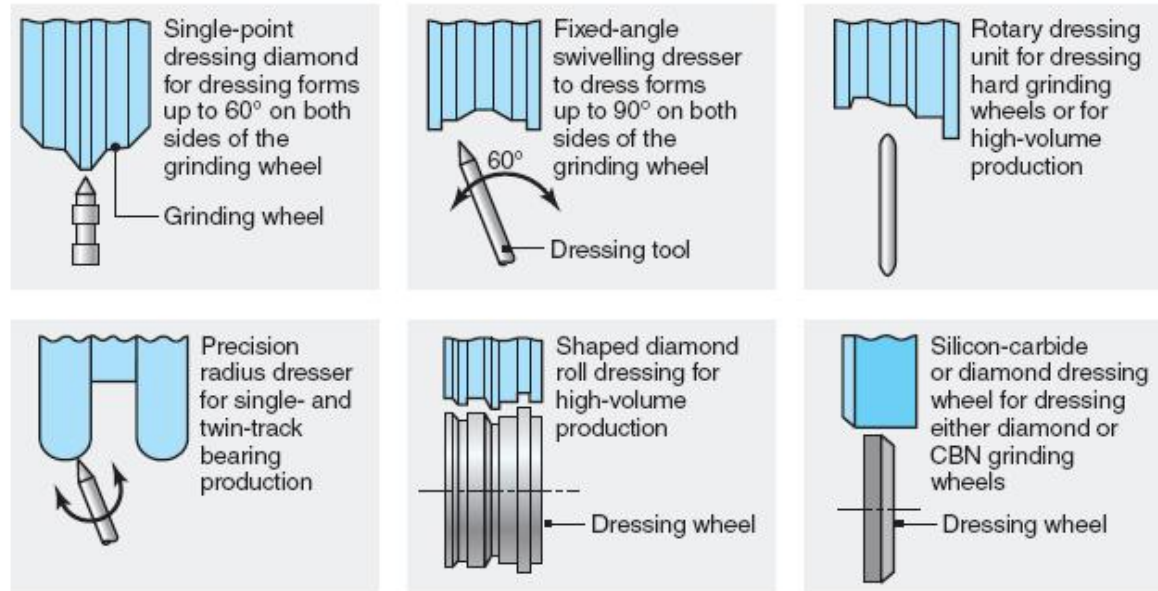

(a)

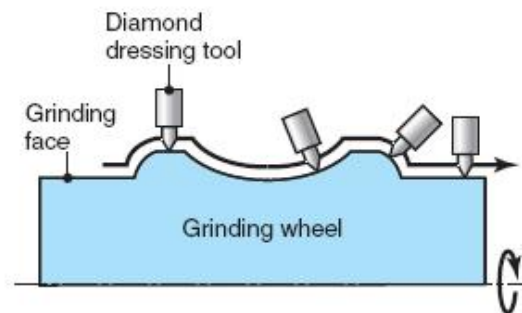

(b) Dr. Juma Al Aydi

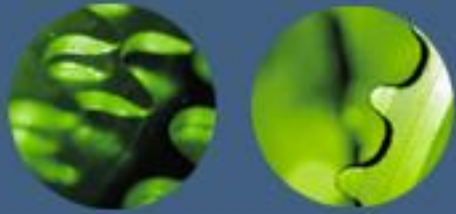

Grinding Operations and Machines

- Surface Grinding
- Cylindrical Grinding
- Internal Grinding
- Centerless Grinding
- Creep-feed Grinding
- Heavy Stock Removal by Grinding
- Grinding fluids

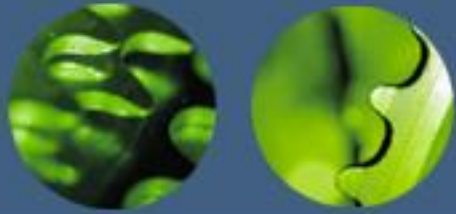

Grinding Operations and Machines

- **Surface Grinding -**
grinding of flat surfaces

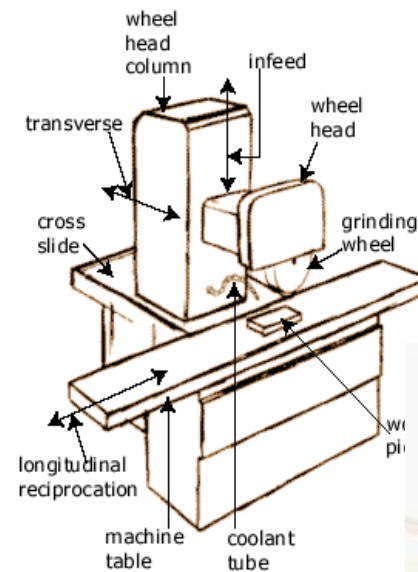

- **Cylindrical Grinding**
– axially ground



The Grinding Process:

Grinding Operations and Machines

36

Surface Grinding

- *Surface grinding* involve the grinding of flat surfaces
- Workpiece is secured on a *magnetic chuck* attached to the worktable of the *grinder*
- Traverse grinding is where the table reciprocates longitudinally and is fed laterally after each stroke.
- In *plunge grinding*, it involves the wheel moving radically *into* the workpiece
- *Vertical spindles* and *rotary tables* allow a number of pieces to be ground in one setup

The Grinding Process: Grinding Operations and Machines

37

Cylindrical Grinding

- Can also produce shapes in which the wheel is dressed to the workpiece form to be ground
- *Non-cylindrical* parts can be ground on rotating workpieces
- Workpiece spindle speed is synchronized between the workpiece and the wheel axis

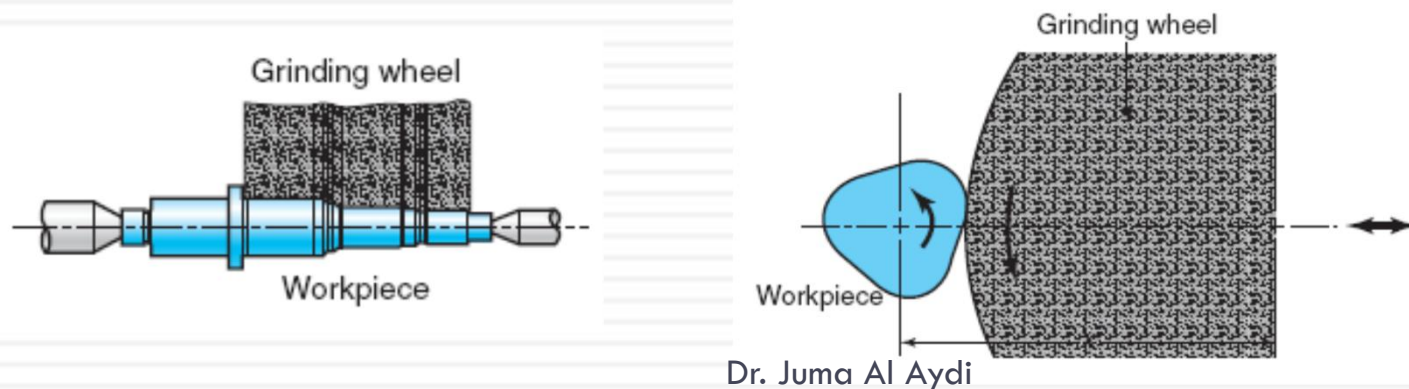

The Grinding Process: Grinding Operations and Machines

38

Cylindrical Grinding

- **Thread grinding** is done on cylindrical grinders using specially dressed wheels matching the shape of the threads

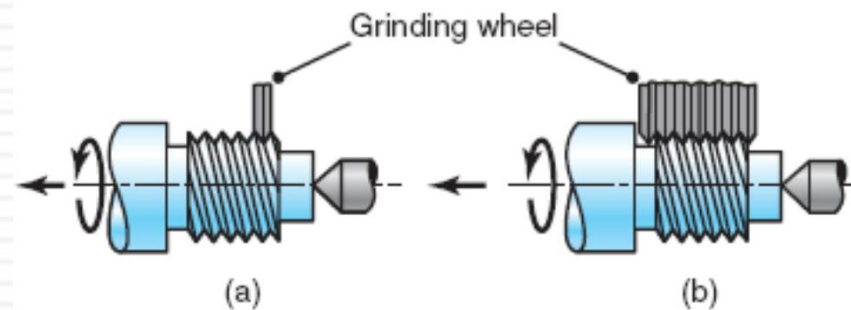

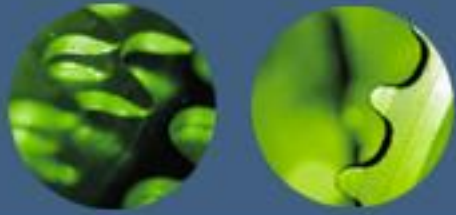

Grinding Operations and Machines

- **Internal Grinding** - grinding the inside diameter of a part
- **Creep-feed Grinding** – large rates of grinding for a close to finished piece

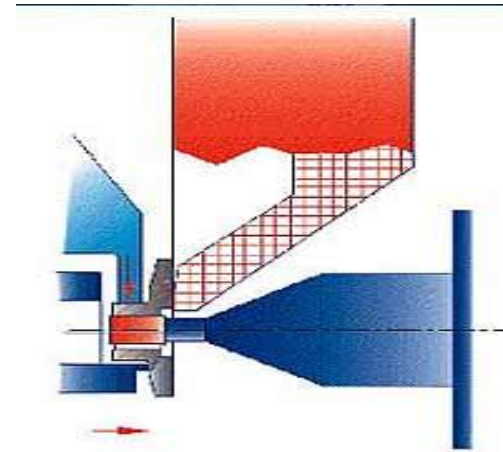

The Grinding Process: Grinding Operations and Machines

40

Internal Grinding

- A small wheel is used to grind the inside diameter of the part
- Internal profiles is ground with profile-dressed wheels that move radially into the workpiece

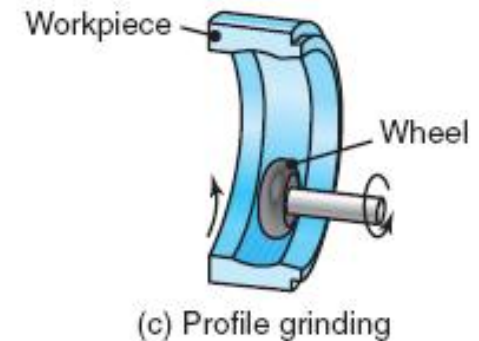
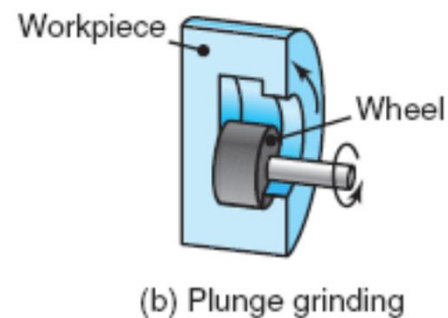
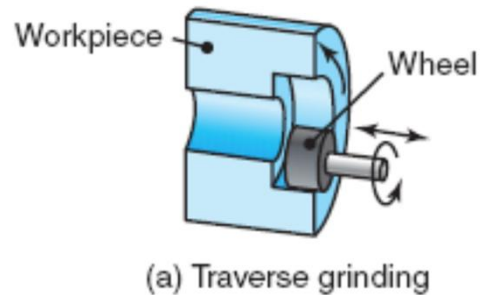

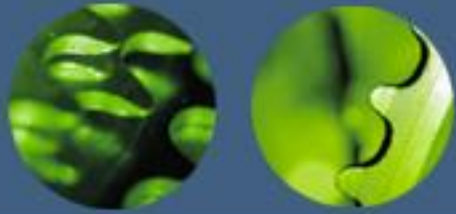

Grinding Operations and Machines

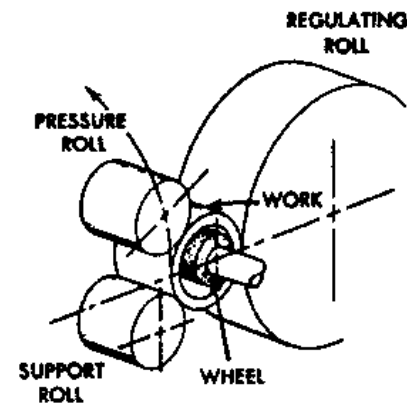
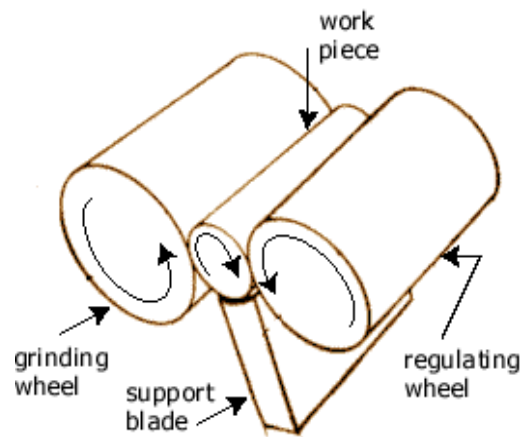

ON CENTER

A

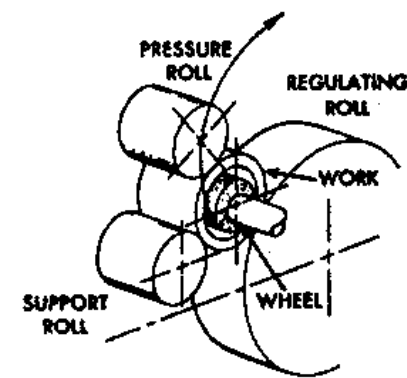

ABOVE CENTER

B

- **Centerless Grinding** – continuously ground cylindrical surfaces

The Grinding Process: Grinding Operations and Machines

42

Creep-feed Grinding

- Grinding can also be used for large-scale metal-removal operations to compete with milling, broaching and planing
- In *creep-feed grinding*, the wheel depth of cut, d , is small and the workpiece speed is low
- To keep workpiece temperatures low and improve surface finish, the wheels are softer grade resin bonded and have an open structure

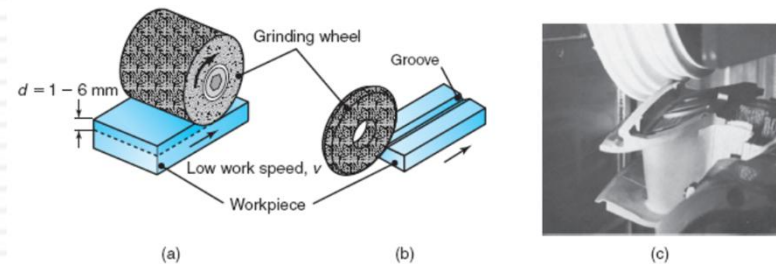

Dr. Juma Al Aydi

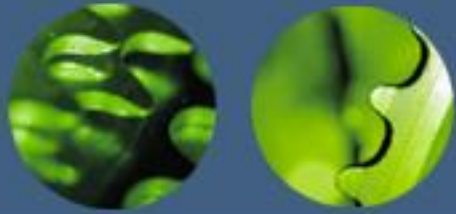

Grinding Operations and Machines

- **Heavy Stock Removal** - economical process to remove large amount of material
- **Grinding Fluids**
 - Prevent workpiece temperature rise
 - Improves surface finish and dimensional accuracy
 - Reduces wheel wear, loading, and power consumption

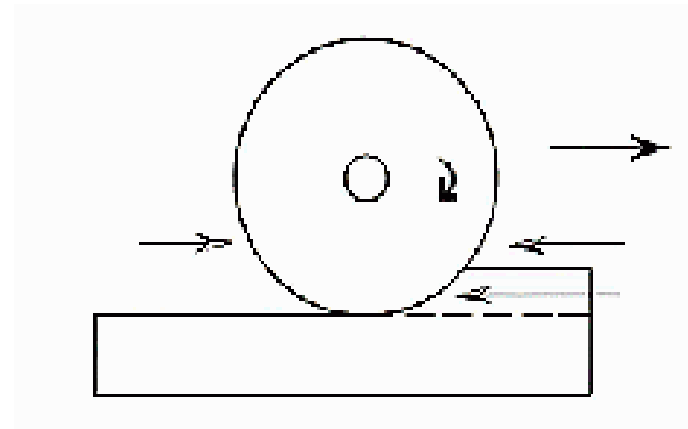

The Grinding Process: Grinding Operations and Machines

44

Grinding Fluids

- Importance of using a fluid:
 1. Reduces temperature rise in the workpiece
 2. Improves part surface finish and dimensional accuracy
 3. Improves the efficiency of the operation
- Grinding fluids are water-based emulsions for grinding and oils for thread grinding

General Recommendations for Grinding Fluids

Material	Grinding fluid
Aluminum	E, EP
Copper	CSN, E, MO + FO
Magnesium	D, MO
Nickel	CSN, EP
Refractory metals	EP
Steels	CSN, E
Titanium	CSN, E

D = dry; E = emulsion; EP = extreme pressure; CSN = chemicals and synthetics; MO = mineral oil; FO = fatty oil. (See also Section 33.7.)

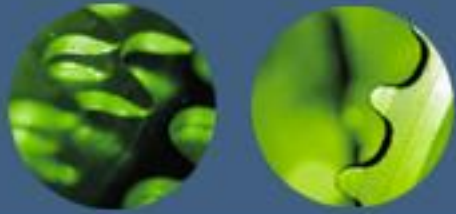

Design Consideration for Grinding

- Part design should include secure mounting into workholding devices.
- Holes and keyways may cause vibration and chatter, reducing dimensional accuracy.
- Cylindrically ground pieces should be balanced. Fillets and radii made as large as possible, or relieved by prior machining.

The Grinding Process: Grinding Chatter

46

- *Chatter* adversely affects surface finish and wheel performance
- **Chatter marks** on ground surfaces can be identified from:
 1. Bearings and spindles of the grinding machine
 2. Non-uniformities in the grinding wheel
 3. Uneven wheel wear
 4. Poor dressing techniques
 5. Using grinding wheels that are not balanced properly
 6. External sources

The Grinding Process: Grinding Chatter

47

- Ways to reduce the tendency for chatter in grinding:
 1. Using soft-grade wheels
 2. Dressing the wheel frequently
 3. Changing dressing techniques
 4. Reducing the material-removal rate
 5. Supporting the workpiece rigidly

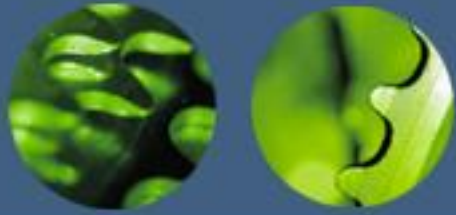

Design Considerations for Grinding

- Long pieces are given better support in centerless grinding, and only the largest diameter may be ground in through-feed grinding.
- Avoid frequent wheel dressing by keeping the piece simple.
- A relief should be include in small and blind holes needing internal grinding.

Design Considerations for Grinding

49

- Specific attention should be given to:
 1. Parts should be designed so that they can be mounted securely
 2. Interrupted surfaces should be avoided as they can cause vibrations and chatter
 3. Parts for cylindrical grinding should be balanced
 4. Short pieces should be avoided as they may be difficult to grind
 5. Design kept simple to avoid frequent form dressing of the wheel
 6. Holes should be avoided



Ultrasonic Machining

50

- Material is removed from a surface by microchipping and erosion with loose, fine abrasive grains in a water slurry
- Best suited for materials that are hard and brittle
- *Form tool* is required for each shape to be produced
- Materials for abrasive grains are boron carbide, aluminum oxide or silicon carbide

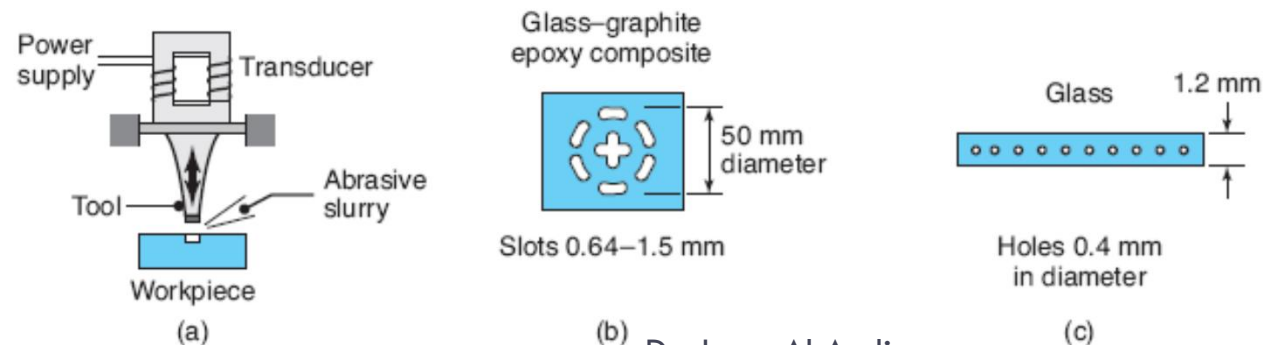

(b) Dr. Juma Al Aydi



Ultrasonic Machining

51

Rotary Ultrasonic Machining

- Abrasive slurry is replaced by metal-bonded diamond abrasives either impregnated or electroplated on the tool surface
- Tool is vibrated ultrasonically and rotated at the same time
- It is being pressed against the workpiece surface at a constant pressure

Ultrasonic Machining

52

Design Considerations for Ultrasonic Machining

- Basic design guidelines:
 1. Avoid sharp profiles, corners, and radii
 2. Holes produced will have some taper
 3. Bottom of the parts should have a backup plate

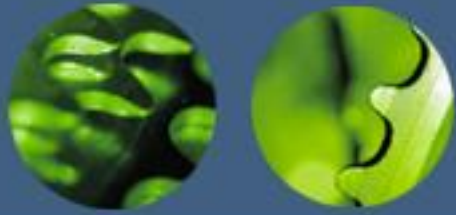

Finishing Operations

- Coated abrasives
- Belt Grinding
- Wire Brushing
- Honing
- Superfinishing
- Lapping
- Chemical-Mechanical Polishing
- Electroplating

Finishing Operations

54

Coated Abrasives

- Coated abrasives are made of aluminum oxide, silicon carbide and zirconia alumina
- Coated abrasives have more open structure than the abrasives on grinding wheels
- They are used to finish flat or curved surfaces of metallic and nonmetallic parts, metallographic specimens, and in woodworking

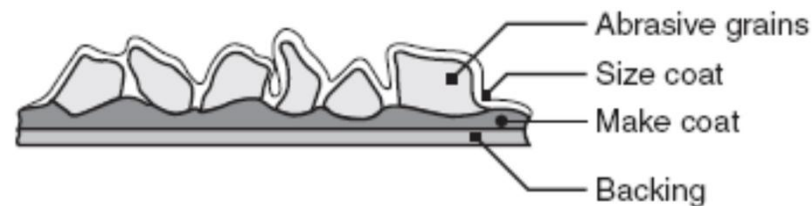

Dr. Juma Al Aydi



Finishing Operations

55

Belt Grinding

- Used as *belts* for high-rate material removal with good surface finish
- Replace conventional grinding operations
- **Microreplication** perform more consistently than conventional coated abrasives and the temperatures involved are lower

Finishing Operations

56

Belt Grinding

- Used as *belts* for high-rate material removal with good surface finish
- Replace conventional grinding operations
- **Microreplication** perform more consistently than conventional coated abrasives and the temperatures involved are lower

Finishing Operations

57

EXAMPLE 26.5

Belt Grinding of Turbine Nozzle Vanes

- Turbine nozzle vanes shown
- The vanes were mounted on a fixture and ground dry at a belt surface speed of 1,800 m/min

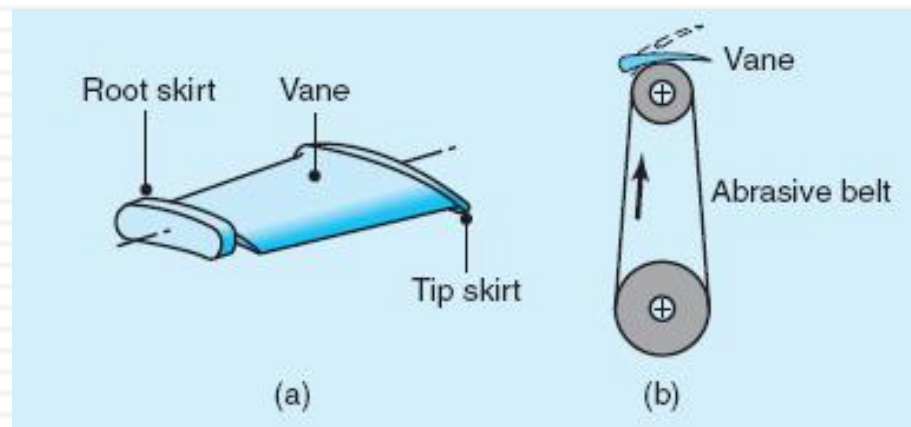

Dr. Juma Al Aydi

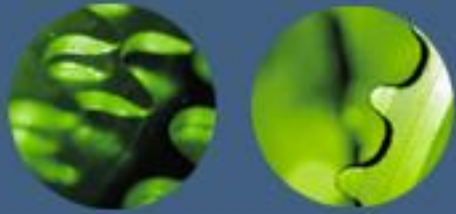

Finishing Operations

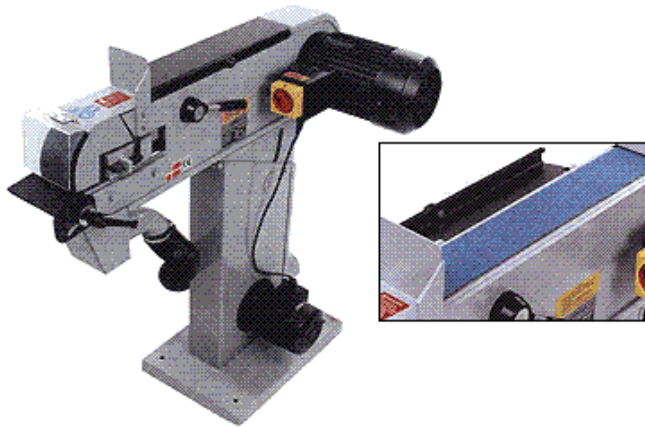
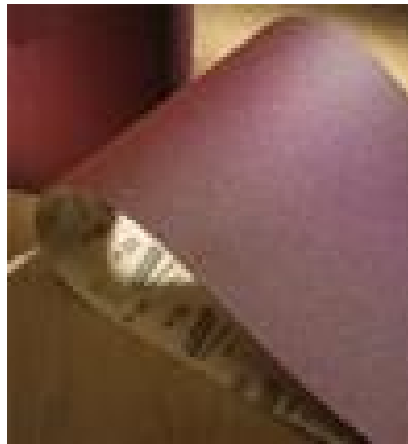

- **Coated Abrasives** – have a more pointed and open structure than grinding wheels
- **Belt Grinding** – high rate of material removal with good surface finish

Finishing Operations

59

Wire Brushing

- Also called *power brushing*
- The workpiece is held against a circular wire brush that rotates
- Wire brushing is used to produce a fine or controlled surface texture

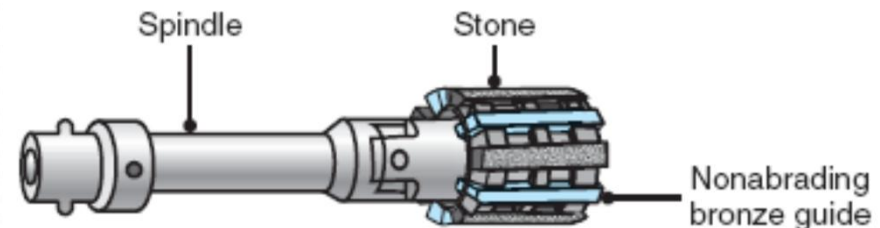

Honing

- Used to improve the surface finish of holes
- Tool has a reciprocating axial motion and produces a crosshatched pattern on the surface of the hole

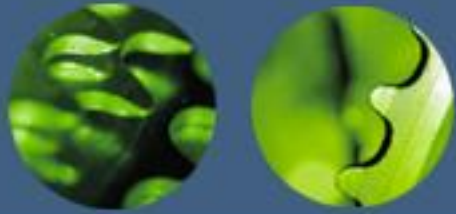

Finishing Operations



- **Wire Brushing** - produces a fine or controlled texture



- **Honing** – improves surface after boring, drilling, or internal grinding

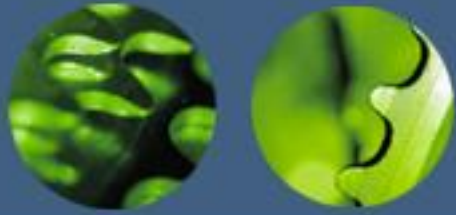

Finishing Operations

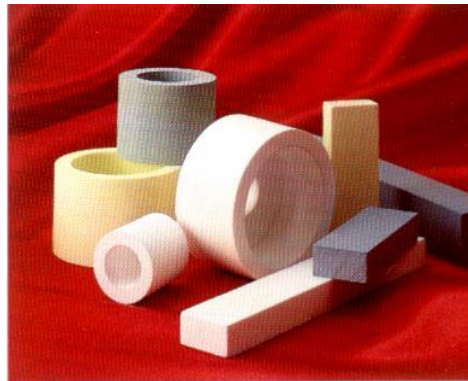

- **Superfinishing** – very light pressure in a different path to the piece

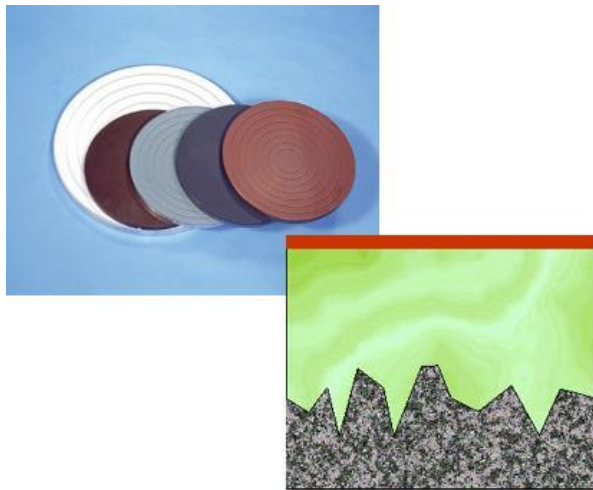

- **Lapping** – abrasive or slurry wears the piece's ridges down softly

Finishing Operations

62

Superfinishing

- Light pressure is applied and the motion of the honing stone has a short stroke
- Motion of the stone is controlled so that the grains do not travel along the same path on the surface

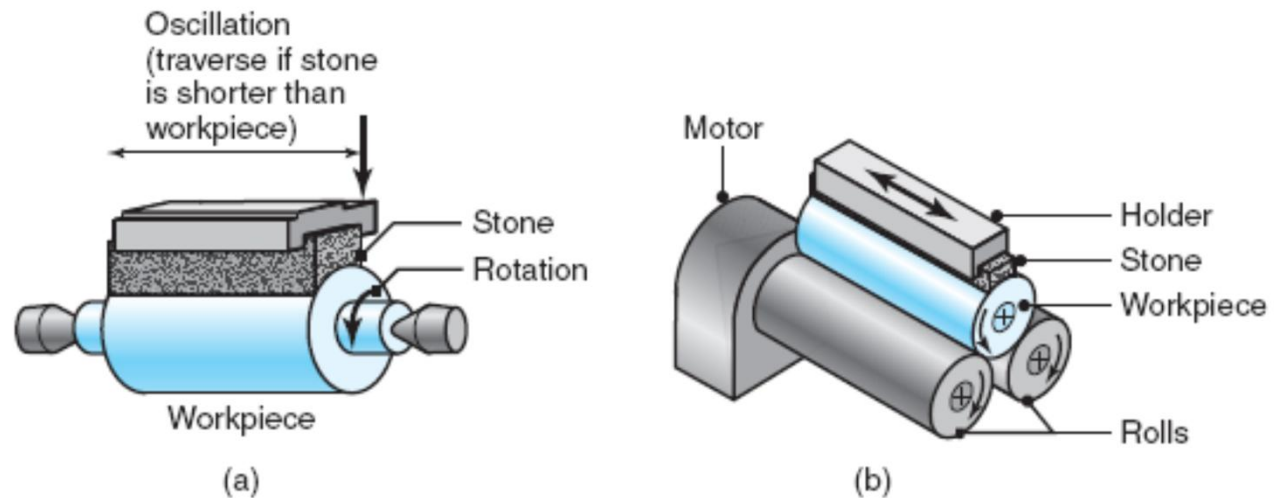

Dr. Juma Al Aydi

Finishing Operations

63

Lapping

- Used for finishing flat, cylindrical, or curved surfaces
- The *lap* is soft and porous and is made of cast iron, copper, leather or cloth
- The abrasive particles are embedded in the lap or carried in a slurry

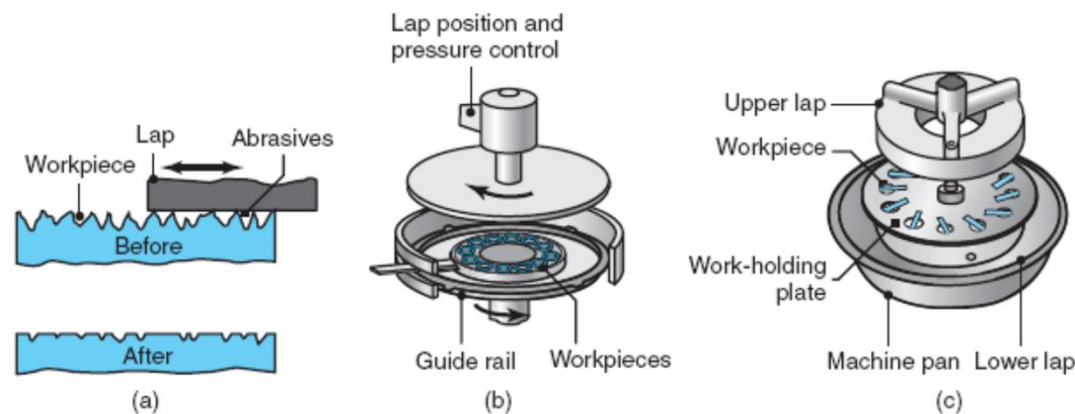

Dr. Juma Al Aydi

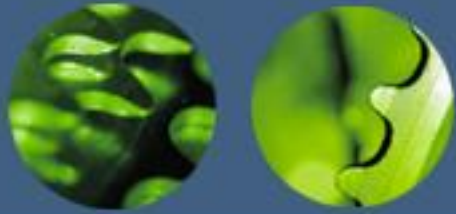

Finishing Operations

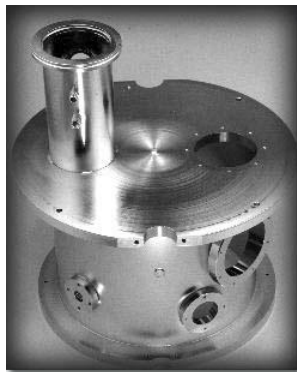
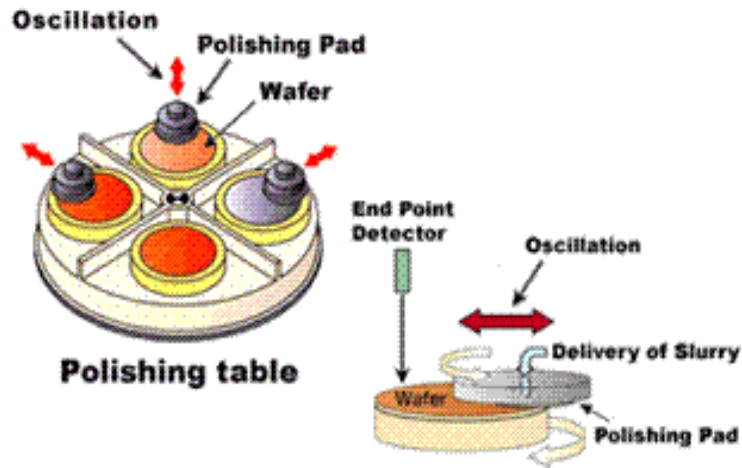

- **Chemical-mechanical Polishing** – slurry of abrasive particles and a controlled chemical corrosive
- **Electropolishing** – an unidirectional pattern by removing metal from the surface

Finishing Operations

65

Polishing

- A process that produces a smooth, lustrous surface finish
- Softening and smearing of surface layers by frictional heating and fine scale abrasive removal from the workpiece surface
- Produce shiny appearance of polished surfaces

Finishing Operations

66

Chemical–mechanical Polishing

- Uses a suspension of abrasive particles in a water-based solution with a controlled corrosion
- Removes material from the workpiece through combined abrasion and corrosion effects
- Major application of this process is the polishing of silicon wafers

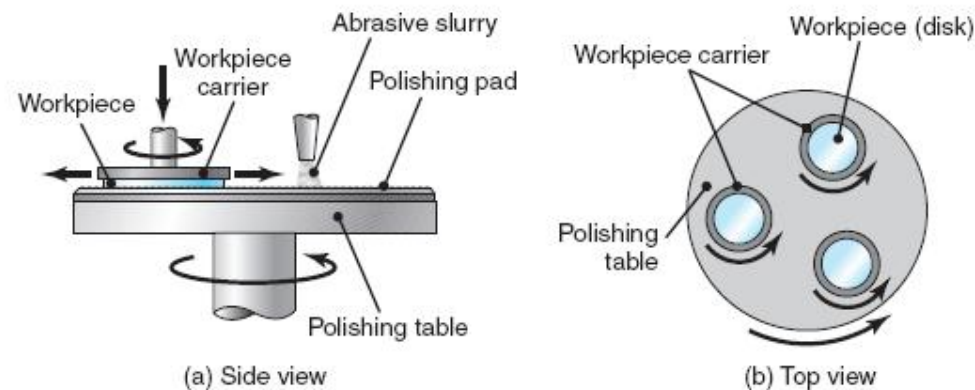

Dr. Juma Al Aydi

Finishing Operations

67

Electropolishing

- Mirrorlike finishes can be obtained on metal surfaces
- No mechanical contact with the workpiece
- For polishing irregular shapes

Polishing in Magnetic Fields

- 2 basic polishing methods:
 1. **Magnetic-float**
 2. **Magnetic-field-assisted**

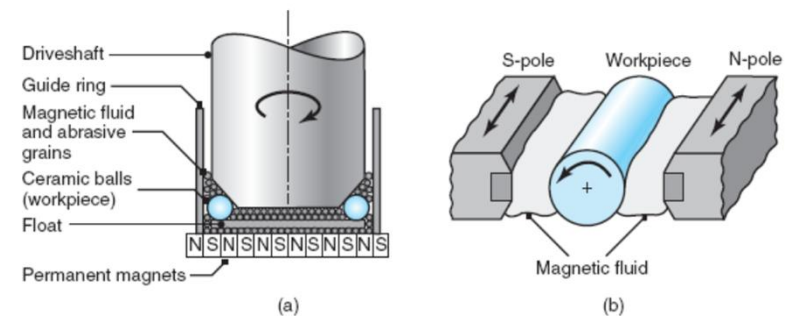

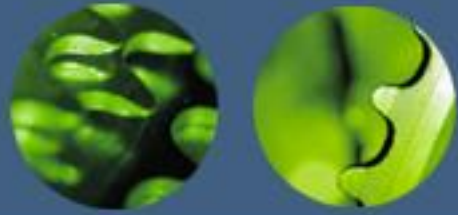

Deburring Operations

- Manual Deburring
- Mechanical Deburring
- Vibratory and Barrel Finishing
- Shot Blasting
- Abrasive-Flow Machining
- Thermal Energy Deburring
- Robotic Deburring

Deburring Operations

69

- **Burrs** are thin ridges developed along the edges of a workpiece from operations
- Burrs can be detected by simple means or visual inspection
- Burrs have several disadvantages:
 1. Jam and misalignment of parts,
 2. Safety hazard to personnel
 3. Reduce the fatigue life of components
 4. Sheet metal have lower bend ability



Deburring Operations

70

- Deburring operations include:
 1. Manual deburring with files and scrapers
 2. Mechanical deburring by machining pieces
 3. Wire brushing
 4. Using abrasive belts
 5. Ultrasonic machining
 6. Electropolishing
 7. Electrochemical machining
 8. Magnetic–abrasive finishing
 9. Vibratory finishing
 10. Shot blasting or abrasive blasting

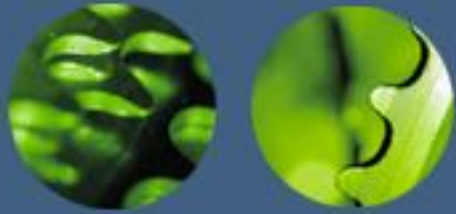

Deburring Operations

- **Vibratory and Barrel Finishing** – abrasive pellets are tumbled or vibrated to deburr
- **Abrasive-flow Machining** – a putty of abrasive grains is forced through a piece

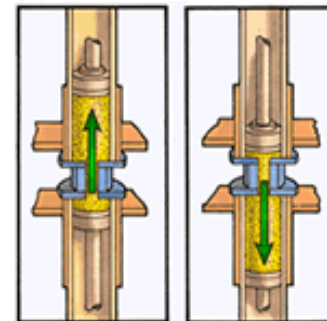

Deburring Operations

72

Vibratory and Barrel Finishing

- Used to remove burrs from large numbers of relatively small workpieces
- Container is *vibrated* or *tumbled* by various mechanical means
- Impact of individual abrasives and metal particles removes the burrs and sharp edges from the parts
- Can be a *dry* or a *wet* process

Deburring Operations

73

Shot Blasting

- Also called **grit blasting**
- Involves abrasive particles propelling by a high-velocity jet of air, or by a rotating wheel, onto the surface of the workpiece
- Surface damage can result if the process parameters are not controlled
- **Microabrasive blasting** consists of small-scale polishing and etching on bench-type units

Deburring Operations

74

Abrasive-flow Machining

- Involves the use of abrasive grains that are mixed in a putty-like matrix
- Movement of the abrasive matrix under pressure erodes away both burrs and sharp corners and polishes the part

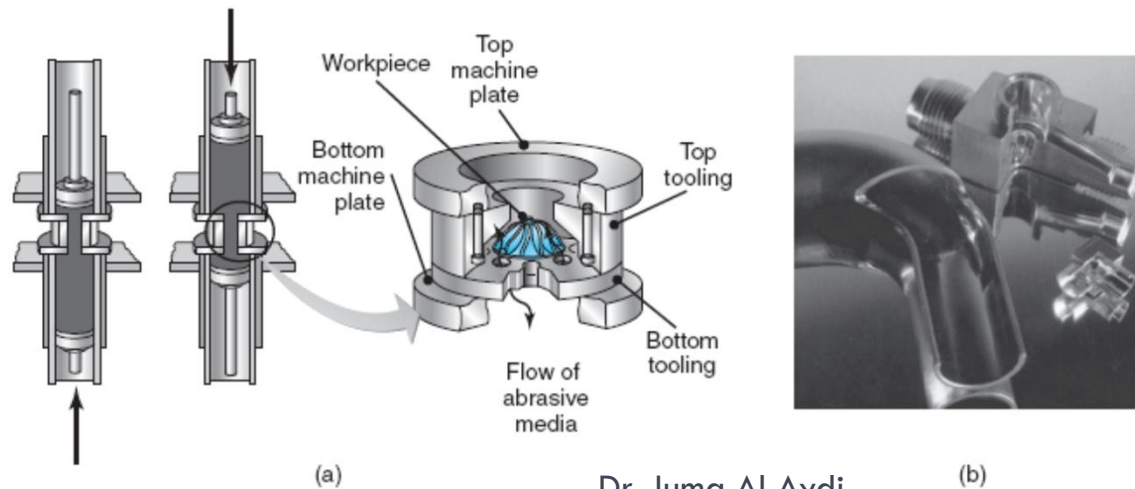

Dr. Juma Al Aydi

Deburring Operations

75

Thermal Energy Deburring

- Consist of placing the part in a chamber and injected with a mixture of natural gas and oxygen
- Drawbacks to the process:
 1. Larger burrs tend to form
 2. Thin and slender parts may distort
 3. Does not polish or buff the workpiece surfaces



Deburring Operations

76

Robotic Deburring

- Deburring and flash removal by *programmable robots*
- Using a force-feedback system for controlling the path and rate of burr removal
- Eliminates tedious and expensive manual labor

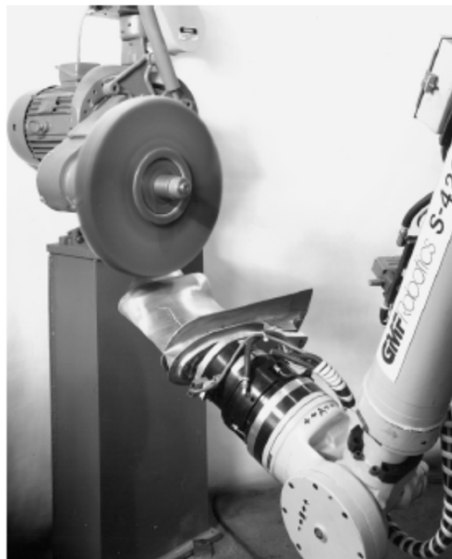

Dr. Juma Al Aydi

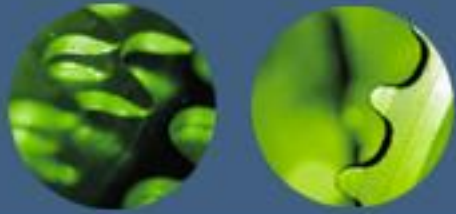

Economics of Abrasive Machining and Finishing Operations

- Creep-feed grinding is an economical alternative to other machining operations.
- The use of abrasives and finishing operations achieve a higher dimensional accuracy than the solitary machining process.
- Automation has reduced labor cost and production times.
- The greater the surface-finish, the more operations involved, increases the product cost.
- Abrasive processes and finishing processes are important to include in the design analysis for pieces requiring a surface finish and dimensional accuracy.